

# Spread Spectrum Oscillator

## Ultra Low Power EMI Reduction Oscillator

SSO5032IxxF

### ■ DESCRIPTION

The SSO5032 is a spread-spectrum Oscillator. The SSO5032 offers unparalleled flexibility in terms of frequency range, frequency accuracy stability, and operating temperature range while simultaneously offering outstanding performance in terms of low jitter. This flexibility and high performance is made available in packages down to 5.0 x 3.2 mm. SSO5032 includes an enable control pin.

### ■ FEATURE

- FCC approved method of EMI attenuation.
- Proprietary Low EMI Phase Modulated Oscillator
- Supply Voltage 3.3V
- Frequency 12M 24M 27M
- Modulation Enable/Disable Function
- 5032 package
- Operating Temperature -40 °C to 85 °C

### ■ Application

SSO5032 is targeted for consumer electronics application such as MFP, STB, DSC, MID, HDMI, LCD panel Camcorder, and other timing sensitive analog video imaging applications. Applications of HDMI, RJ45 port has good compatibility

### ■ BLOCK DIAGRAM

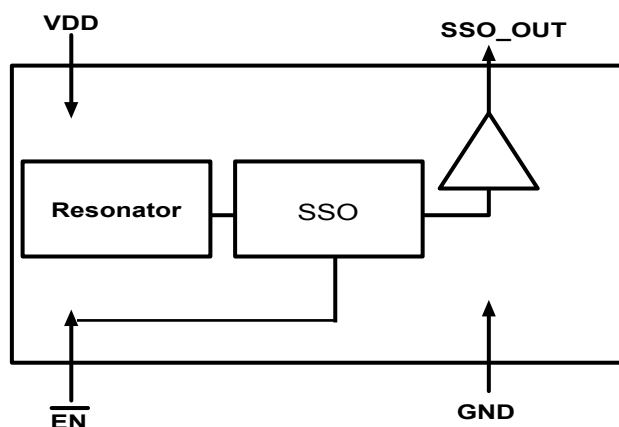

■ PIN ASSIGNMENT

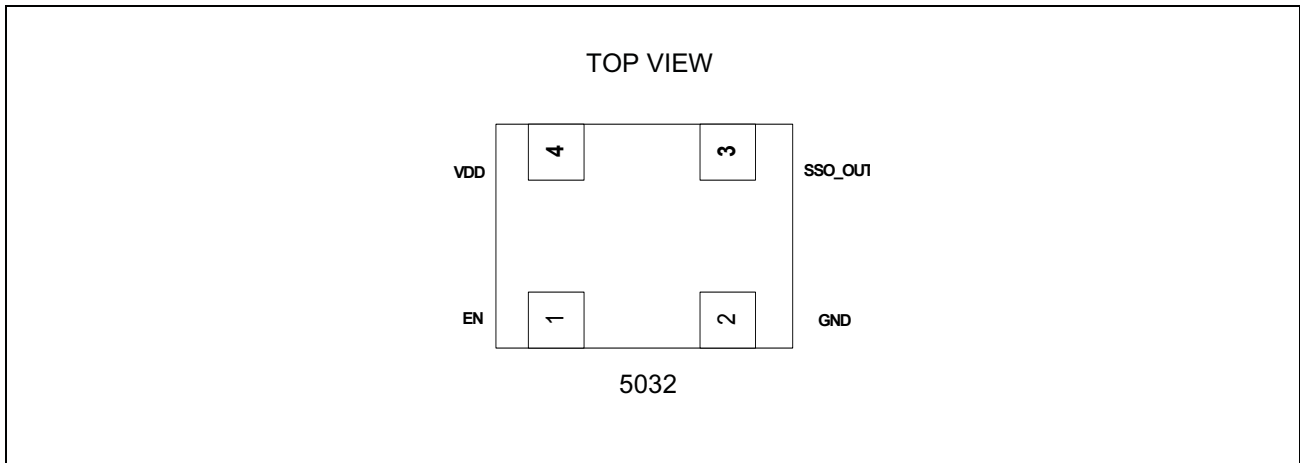

■ PIN DESCRIPTION

Pin name	I/O	Pin no.	Description
EN	I	1	Modulation Enable Pin.H:Enable,Internal pull-High Resistor
GND		2	GND pin
OUTPUT	I	3	Phade modulated buffered output.
VDD		4	Power supply voltage pin

■ ABSOLUTE MAXIMUM RATINGS

Parameter	Symbol	Rating		Unit
		Min	Max	
Power supply voltage*	$V_{DD}$	- 0.5	+ 4.5	V
Output voltage*	$V_o$	$V_{SS} - 0.5$	$V_{DD} + 0.5$	V
Storage temperature	$T_{ST}$	- 55	+ 125	°C
Operation junction temperature	$T_J$	-40	+85	°C

■ ELECTRICAL CHARACTERISTICS

• DC Characteristics

(Ta = -40°C to +85 °C, V<sub>DD</sub> = 3.3 V ± 0.3 V, V<sub>SS</sub> = 0.0 V)

Parameter	Symbol	Pin	Conditions	Value			Unit
				Min	Typ	Max	
Output voltage	V <sub>OH</sub>	CKOUT	“H” level output I <sub>OH</sub> = - 4 mA	0.9V <sub>DD</sub>	—	V <sub>DD</sub>	V
	V <sub>OL</sub>	CKOUT	“L” level output I <sub>OL</sub> = 4 mA	V <sub>SS</sub>	—	0.1V <sub>DD</sub>	V
Load capacitance	C <sub>L</sub>	CKOUT	12 MHz to 27 MHz	—	—	15	pF
Power supply current	I <sub>CC</sub>	V <sub>DD</sub>	No load capacitance at 27 MHz	—	6	10	mA
Power down current	I <sub>pd</sub>	V <sub>DD</sub>	Input clock stopping	—	4	—	μA

• AC Characteristics

(Ta = -40°C to +85 °C, V<sub>DD</sub> = 3.3 V ± 0.3 V, V<sub>SS</sub> = 0.0 V)

Parameter	Symbol	Pin	Conditions	Value			Unit
				Min	Typ	Max	
Output clock duty cycle	t <sub>dcc</sub>	CKOUT	1.5 V	45	—	55	%
Output Rise Time			between 20% to 80%		0.9		nS
Output Fall Time			between 80% to 20%		0.9		nS
Cycle-cycle jitter	t <sub>jc</sub>	CKOUT	No load capacitance, Ta = + 25 °C, V <sub>DD</sub> = 3.3 V	—	—	2	ps-rms

■ **OUTPUT CLOCK DUTY CYCLE ( $t_{bCC} = t_b/t_a$ )**

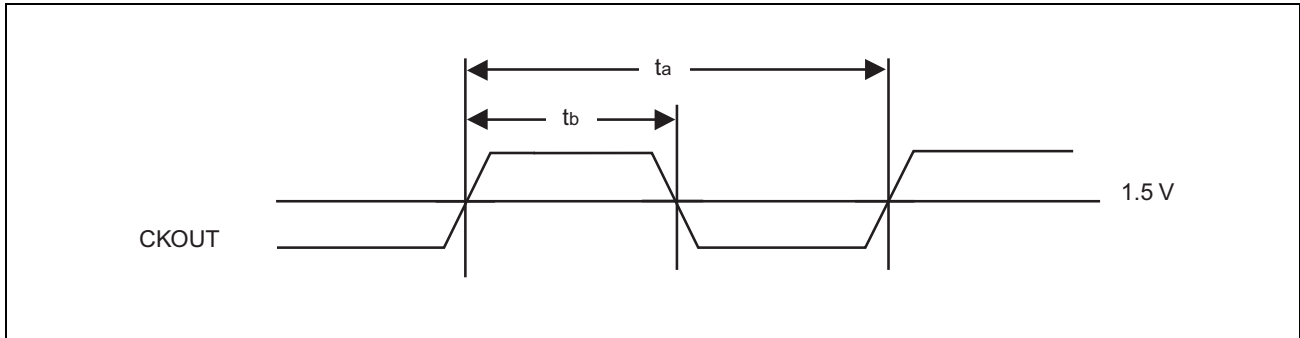

■ **OUTPUT SLEW RATE (SR)**

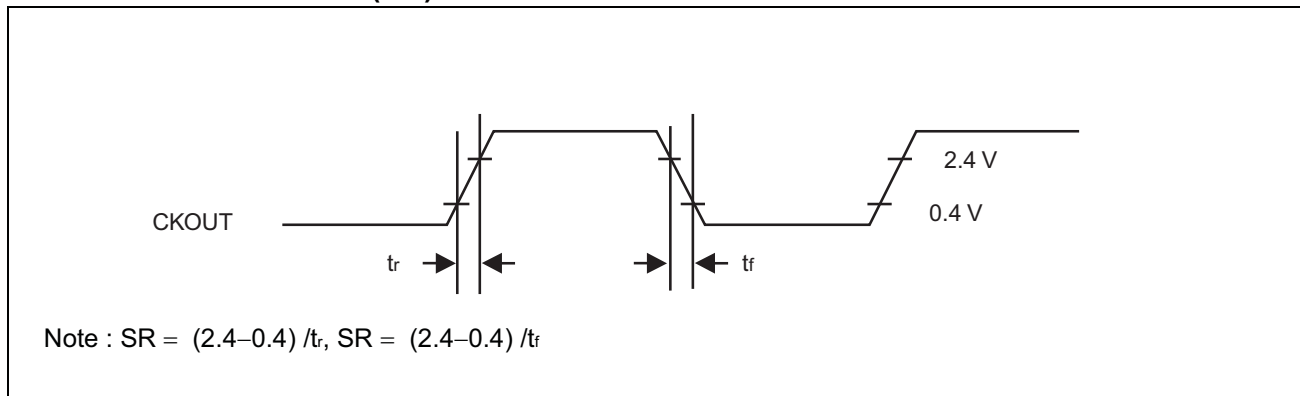

■ **Functional Table**

Vdd(V)	Freq(MHz)	Deviation (%)
3.3	12	±0.4
	24	±0.5
	27	±0.55

■ Center spread

Spectrum is spread (modulated) by centering on the input frequency.

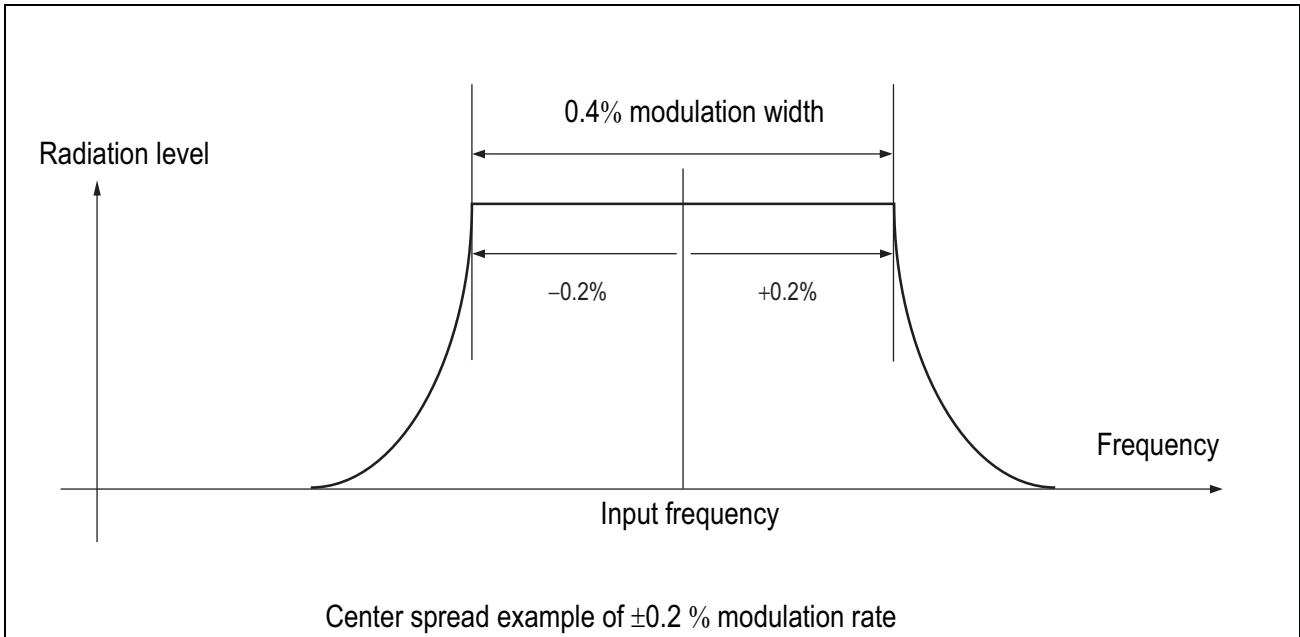

■ Diagram of CLK spread

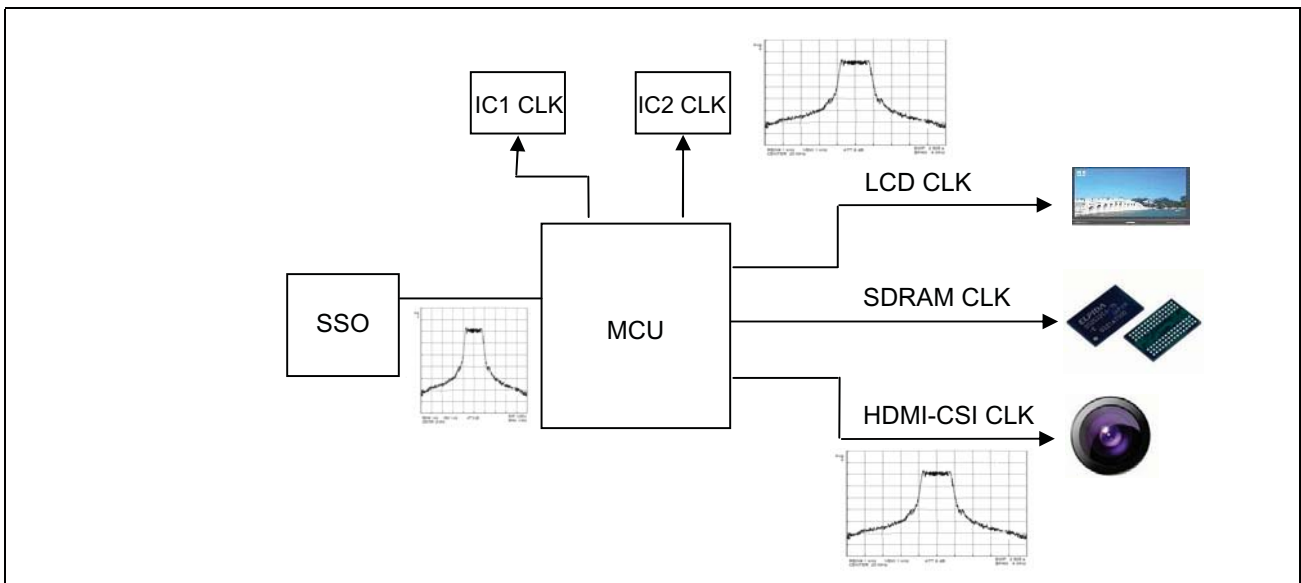

■ Dimensions

5.0 x 3.2 x 0.75 mm

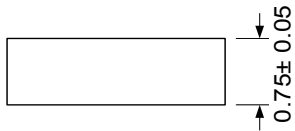
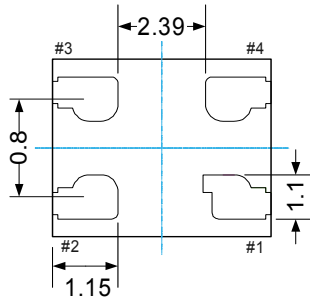
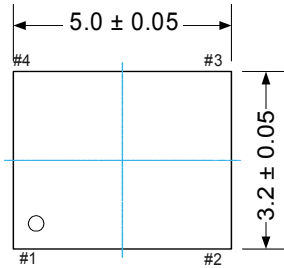

■ Recommended Land Pattern (Unit: mm)

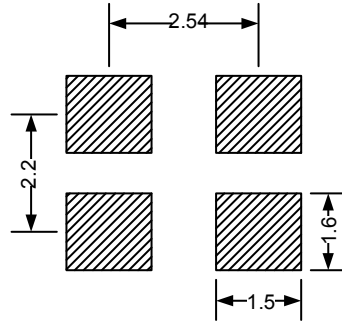

■ Device Ordering Information

SSO 5032 I XX F

