

FEATURES

- Advanced Oscillator Design for Wide Frequency Coverage
- 3 LVCMOS Outputs
- 12 mA Output Drive Strength
- Input/Output Frequency:
 - Fundamental Crystal: 10MHz to 40MHz
- Very Low Jitter and Phase Noise
- Low Current Consumption
- Single 1.62V to 3.63V Power Supply
- Available in SOP-8L GREEN/RoHS Compliant Package

DESCRIPTION

The SVD215-37 is an advanced oscillator fanout buffer design for high performance, low-power applications. The SVD215-37 accepts a fundamental crystal input of 10MHz to 40MHz and produces three LVCMOS outputs of the same frequency. The Output Enable (OE) function can be used to tri-state the outputs.

The SVD251-37 offers the best phase noise and jitter performance and lowest power consumption of any comparable IC.

PACKAGE PIN CONFIGURATION

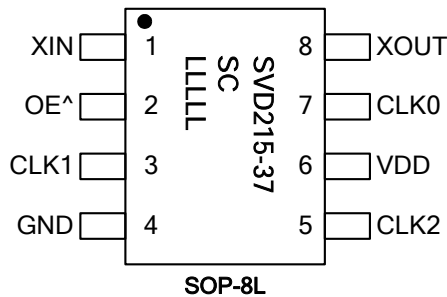

*Note: LLLLL designates lot number

BLOCK DIAGRAM

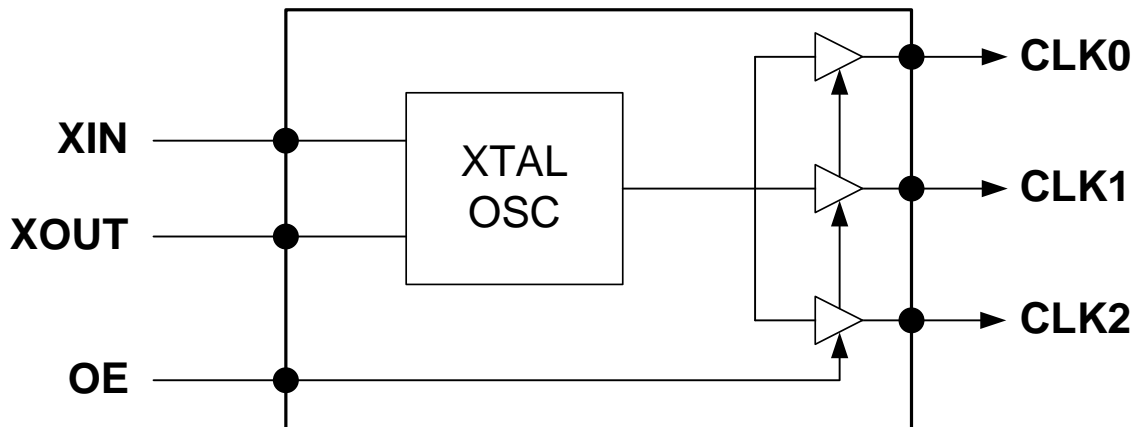

PIN DESCRIPTION

Name	SOP-8L	Type	Description
XIN	1	I	Crystal input
OE	2	I	Output enable input. This pin has internal pull-up resistor. All outputs will be tri-stated when pulled low.
CLK1	3	O	Output clock
GND	4	P	Ground connection
CLK2	5	O	Output clock
VDD	6	P	Power supply
CLK0	7	O	Output clock
XOUT	8	I	Crystal output

* **Note:** This pin includes an internal 60KΩ pull up.

LAYOUT RECOMMENDATIONS

The following guidelines are to assist you with a performance optimized PCB design:

Signal Integrity and Termination Considerations

- Keep traces short!
- Trace = Inductor. With a capacitive load this equals ringing!
- Long trace = Transmission Line. Without proper termination this will cause reflections (looks like ringing).
- Design long traces as “striplines” or “microstrips” with defined impedance.
- Match trace at one side to avoid reflections bouncing back and forth.

Decoupling and Power Supply Considerations

- Place decoupling capacitors as close as possible to the V_{DD} pin(s) to limit noise from the power supply
- Multiple V_{DD} pins should be decoupled separately for best performance.
- Addition of a ferrite bead in series with V_{DD} can help prevent noise from other board sources
- Value of decoupling capacitor is frequency dependent. Typical value to use is 0.1μF.

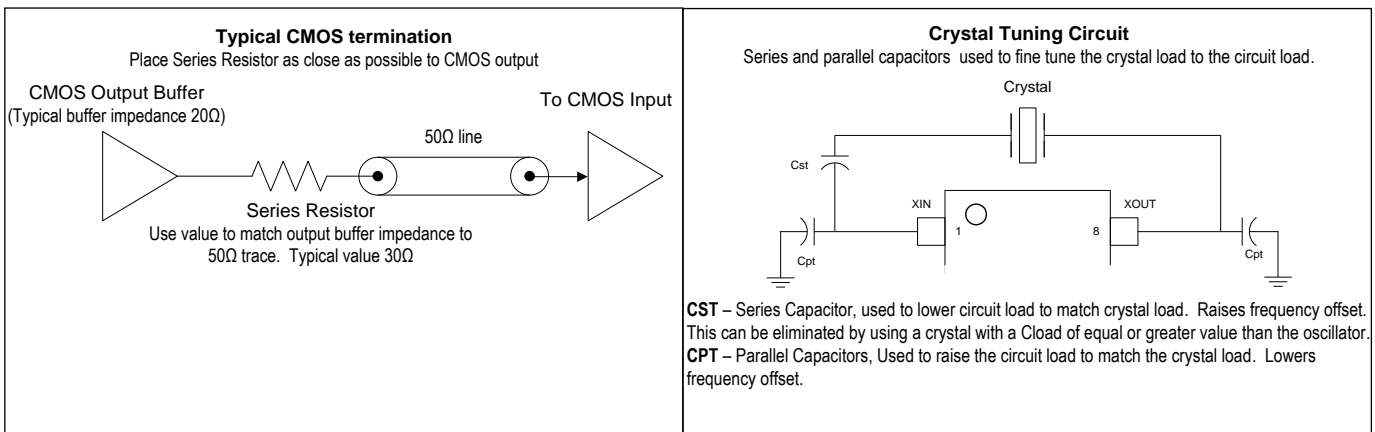

ELECTRICAL SPECIFICATIONS

ABSOLUTE MAXIMUM RATINGS

PARAMETERS	SYMBOL	MIN.	MAX.	UNITS
Supply Voltage Range	V_{DD}	-0.5	4.6	V
Input Voltage Range	V_I	-0.5	$V_{DD}+0.5$	V
Output Voltage Range	V_O	-0.5	$V_{DD}+0.5$	V
Storage Temperature	T_S	-65	150	°C
Ambient Operating Temperature*		-40	85	°C

Exposure of the device under conditions beyond the limits specified by Maximum Ratings for extended periods may cause permanent damage to the device and affect product reliability. These conditions represent a stress rating only, and functional operations of the device at these or any other conditions above the operational limits noted in this specification is not implied. *Operating temperature is guaranteed by design. Parts are tested to commercial grade only.

AC SPECIFICATIONS

PARAMETERS	CONDITIONS	MIN.	TYP.	MAX.	UNITS
Crystal Input Frequency	Fundamental Crystal	10		40	MHz
Settling Time	At power-up ($V_{DD} \geq 1.62V$)			5	ms
Output Enable Time	OE Function; $T_a=25^\circ C$, 10pF Load			10	ns
V_{DD} Sensitivity	Frequency vs. V_{DD} , $\pm 10\%$	-1		1	ppm
Output Rise Time	15pF Load, 10/90% V_{DD} , 3.3V		2	3	ns
Output Fall Time	15pF Load, 90/10% V_{DD} , 3.3V		2	3	ns
Output to Output Skew	Under all conditions			250	ps
Duty Cycle	Under all conditions	45	50	55	%

DC SPECIFICATIONS

PARAMETERS	SYMBOL	CONDITIONS	MIN	TYP	MAX	UNITS
Supply Current, Dynamic	I_{DD}	$V_{DD} = 3.3V$, 25MHz, No Load		4		mA
		$V_{DD} = 2.5V$, 25MHz, No Load		3		mA
		$V_{DD} = 1.8V$, 25MHz, No Load		2		mA
Supply Current, Standby	I_{DD_SB}	OE Pin Pulled Low, 25MHz, 3.3V			0.6	mA
Operating Voltage	V_{DD}		1.62		3.63	V
Output Low Voltage	V_{OL}	$I_{OL} = +12mA$, 3.3V			0.4	V
Output High Voltage	V_{OH}	$I_{OH} = -12mA$, 3.3V	2.4			V
Output Current	I_{OSD}	$V_{OL} = 0.4V$, $V_{OH} = 2.4V$	12			mA

CRYSTAL SPECIFICATIONS

PARAMETERS	SYMBOL	MIN.	TYP.	MAX.	UNITS
Fundamental Crystal Resonator Frequency	F_{XIN}	10		40	MHz
Crystal Loading Rating	$C_L (xtal)$		8.5		pF
Maximum Sustainable Drive Level				200	μ W
Operating Drive Level			50		μ W
Crystal Shunt Capacitance	C_0			3	pF
Effective Series Resistance	ESR			30	Ω

PACKAGE DRAWINGS (GREEN PACKAGE COMPLIANT)

SOP-8L

Symbol	Dimension in MM	
	Min.	Max.
A	1.35	1.75
A1	0.10	0.25
A2	1.25	1.50
B	0.33	0.53
C	0.19	0.27
D	4.80	5.00
E	3.80	4.00
H	5.80	6.20
L	0.40	0.89
e	1.27 BSC	

ORDERING INFORMATION (GREEN PACKAGE COMPLIANT)

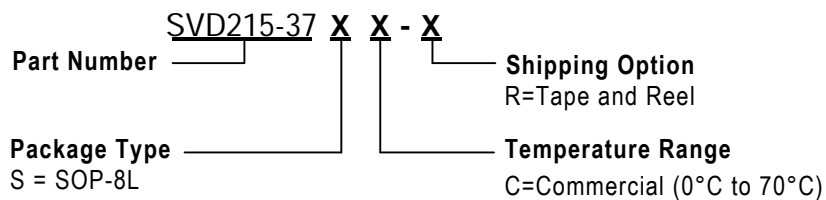

Order Number	Marking	Package Option
SVD215-37SC-R	SVD215-37SC-R	8-Pin SOP-8L (Tape and Reel)